



DC COMPONENTS CO., LTD.

RECTIFIER SPECIALISTS

RS3A
THRU
RS3M

TECHNICAL SPECIFICATIONS OF FAST RECOVERY RECTIFIER

VOLTAGE RANGE - 50 to 1000 Volts CURRENT - 3.0 Amperes

FEATURES

- * Ideal for surface mounted applications
- * Low leakage current
- * Glass passivated junction
- * High efficiency
- * Fast reverse recovery time

MECHANICAL DATA

- * Case: Molded plastic
- * Epoxy: UL 94V-0 rate flame retardant
- * Terminals: Solder plated, solderable per MIL-STD-750, Method 2026
- * Polarity: As marked
- * Mounting position: Any
- * Weight: 0.03 gram

MAXIMUM RATINGS AND ELECTRICAL CHARACTERISTICS

Rating at 25°C ambient temperature unless otherwise specified
Single phase, half wave 60 HZ, resistive or inductive load.
For capacitive load, derate current by 20%.



SMC(DO-214AB)

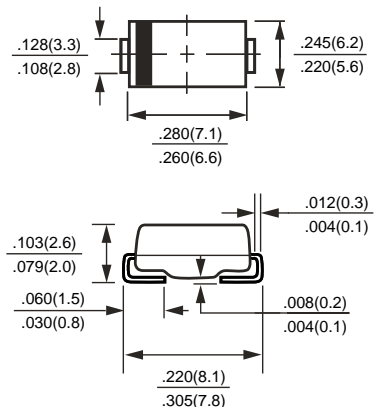

Dimensions in inches and (millimeters)

	SYMBOL	RS3A	RS3B	RS3D	RS3G	RS3J	RS3K	RS3M	UNITS
Maximum Recurrent Peak Reverse Voltage	V _{RRM}	50	100	200	400	600	800	1000	Volts
Maximum RMS Voltage	V _{RMS}	35	70	140	280	420	560	700	Volts
Maximum DC Blocking Voltage	V _{DC}	50	100	200	400	600	800	1000	Volts
Maximum Average Forward Rectified Current at T _A = 65°C	I _O	3.0							Amps
Peak Forward Surge Current I _{FM} (surge): 8.3 ms single half sine-wave superimposed on rated load (JEDEC method)	I _{FSM}	100							Amps
Maximum Forward Voltage at 3.0A DC	V _F	1.3							Volts
Maximum DC Reverse Current at Rated DC Blocking Voltage	I _R	@ T _A = 25°C	5.0						μAmps
		@ T _A = 125°C	150						
Maximum Reverse Recovery Time (Note 1)	t _{rr}	150				250			nSec
Typical Thermal Resistance (Note 2)	R _{θJA}	60							°C/W
Typical Junction Capacitance (Note 3)	C _J	60							pF
Operating and Storage Temperature Range	T _J , T _{STG}	-55 to +150							°C

- NOTES : 1. Test Conditions: I_F=0.5A, I_R=1.0A, I_{RR}=0.25A.
2. P.C.B. mounted with 0.5x0.5 in² (12.7x12.7mm²) copper pads to each terminal.
3. Measured at 1MHz and applied reverse voltage of 4VDC.

RATING AND CHARACTERISTIC CURVES (RS3A THRU RS3M)

FIG. 1 - TYPICAL FORWARD CURRENT DERATING CURVE

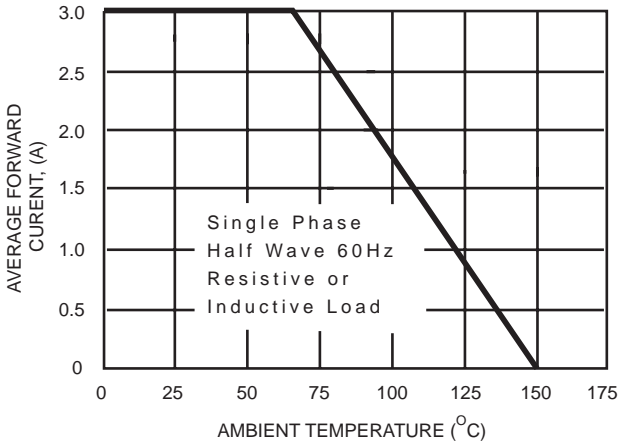

FIG. 2 - TYPICAL INSTANTANEOUS FORWARD CHARACTERISTICS

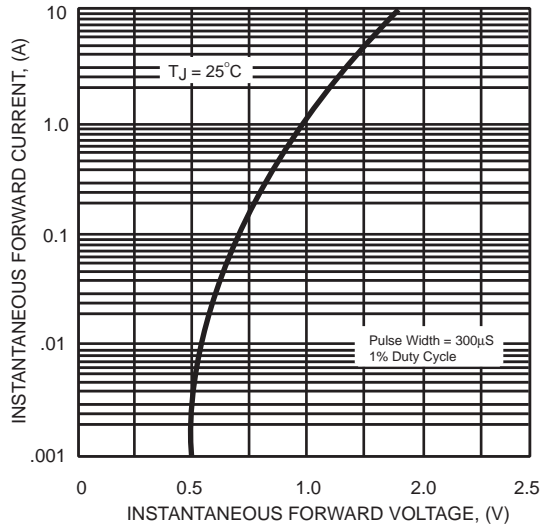

FIG. 3 - MAXIMUM NON-REPETITIVE FORWARD SURGE CURRENT

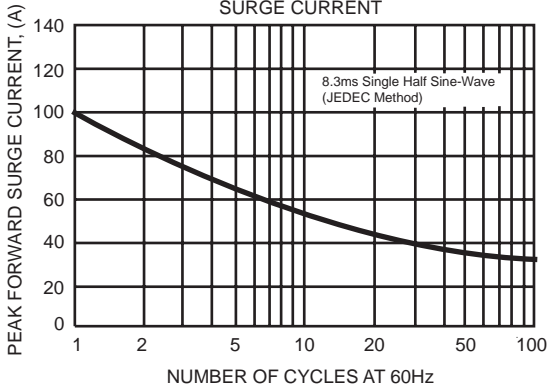

FIG. 4 - TYPICAL REVERSE CHARACTERISTICS

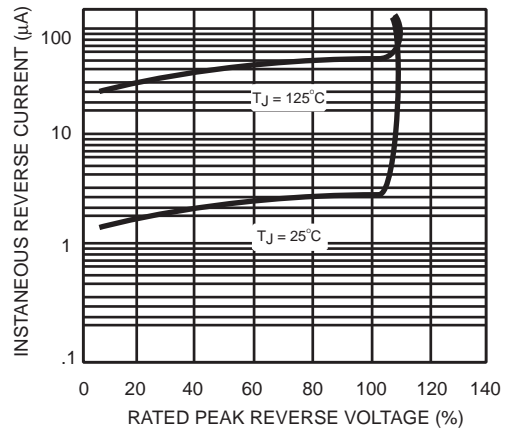

FIG. 5 - TYPICAL JUNCTION CAPACITANCE

